

**AGILE 150**  
**RS 120**  
**DRS 120**  
**RSP 80**

**Hardware for  
Tempered Glass  
Sliding Systems**



# Hardware for Tempered Glass Sliding Systems



## CONTENTS

- 3-8 DORMA AGILE 150/150 Syncro
- 9-14 DORMA RS 120/120 Syncro/DRS 120
- 15-17 DORMA RSP 80
- 18 General Accessories
- 19 Metric/English conversion guide

## DORMA AGILE 150/AGILE 150 Syncro

### Sleek design – sophisticated technology

#### Compact and durable

The AGILE 150 system, part of a new generation of high performance glass panel sliding door accessories from DORMA Glas, combines versatility and durability with sleek European design. The AGILE 150 system operates on a compact track with the roller assembly hidden inside. The track can be mounted on a wall, ceiling or—for the sleek appearance of no track at all—recessed into the ceiling to give the appearance of an all glass sliding door. In addition to its aesthetic benefits, the AGILE 150 system provides superior versatility in installation and maintenance. No glass drilling or machining is required for installation.

#### Minimal gap

The compact dimensions of the AGILE 150 track profile and its enclosed roller assembly allow for minimal clearances between the glass and wall or glass/glass components.



#### Sophisticated track roller technology

The AGILE 150 meets a wide range of demanding customer requirements. Just two maintenance-free clamp-type carriers support

and transport glass panels weighing up to 330 lb (150 kg). The carriers use the same track roller technology as the DORMA HSW horizontal sliding wall systems, which have proven successful over many years. Regarding ease of operation, AGILE satisfies the Class 3 criteria of EN 1527—a force equivalent to just 4% max. of the door mass needs to be applied in order to overcome initial friction and set the door in motion. Even large doors can be operated with minimal effort.

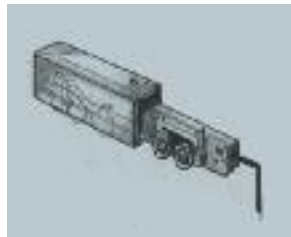

#### Reliable stop

Specially developed catch-type buffers gently decelerate the panels and reliably hold them in both their closed and opened states.

#### Elegant floor guide

The AGILE 150 features an attractive zinc die cast floor guide that can be adjusted for different glass sizes. It uses a rotating plastic insert to safely guide glass elements from 5/16" (8 mm) to 9/16" (14 mm) thick.

#### One system – many solutions

The AGILE 150 is truly versatile. The system can be mounted at the wall, to the ceiling, or along a header in



either its single-panel or double-panel configuration, and with or without fixed sidelites.

#### No glass preparation

With the AGILE 150, drilling and cutting glass panels is unnecessary. Using its extensive expertise in glass fabrication, DORMA has designed the fittings so that a simple clamping action safely secures the panels. The uncomplicated installation is simple and quick. The standard variable clamp-type carriers can accommodate glass thicknesses from 3/8" (10 mm) to 1/2" (12 mm). Even after installing the glass panels, the clamp-type carriers enable you to make vertical adjustments of +/- 3/16" (5 mm) as required.

#### Long service life

To ensure a long service life for the AGILE 150, DORMA has subjected the system to extensive tests involving more

than 100,000 operating cycles (performed to DIN EN 1527). And because it is highly corrosion resistant, you can install and use the AGILE 150 in damp areas with complete confidence.

#### Convenient Syncro version

The AGILE system is also available in a Syncro version that makes use of a virtually invisible and thoroughly proven cable and pulley return system. In this configuration, double-paneled sliding door sets open and close as bi-parting doors when just one of the panels is operated.

Typical assemblies – version without sidelite

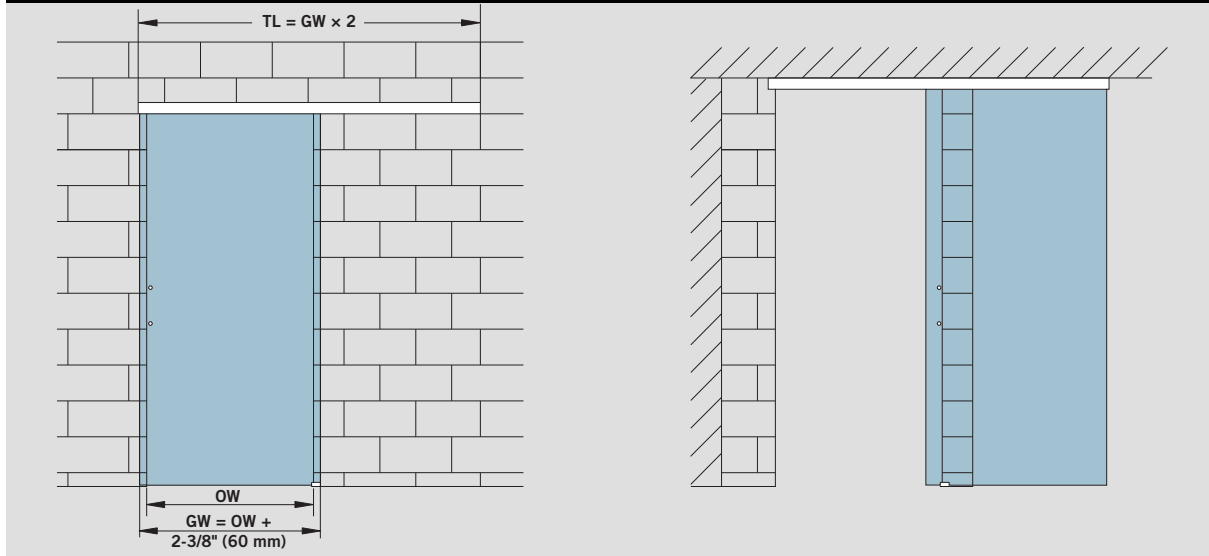

Features and Data

**DORMA AGILE 150**

For installations with one or two door leaves, mounted to wall or ceiling; for 3/8" (10 mm) and 1/2" (12 mm) glass thickness

**Max. weight of door leaves**  
330 lb (150 kg)

**Calculation of glass height**  
GH = OH - 1-11/16" (43 mm)  
or  
GH = DLO + 3/4" (20 mm)  
(see drawing)

**Calculation of glass width**  
GW = OW + 2-3/8" (60 mm)  
[min. 19-11/16" (500 mm)]

**Torque for screws in the clamp-carriers**  
9 lb-ft (12 Nm)

- GW = Glass width
- TL = Track length
- GH = Glass height
- OH = Opening height
- OW = Opening width
- DLO = Daylight opening  
(bottom of track to finished floor)

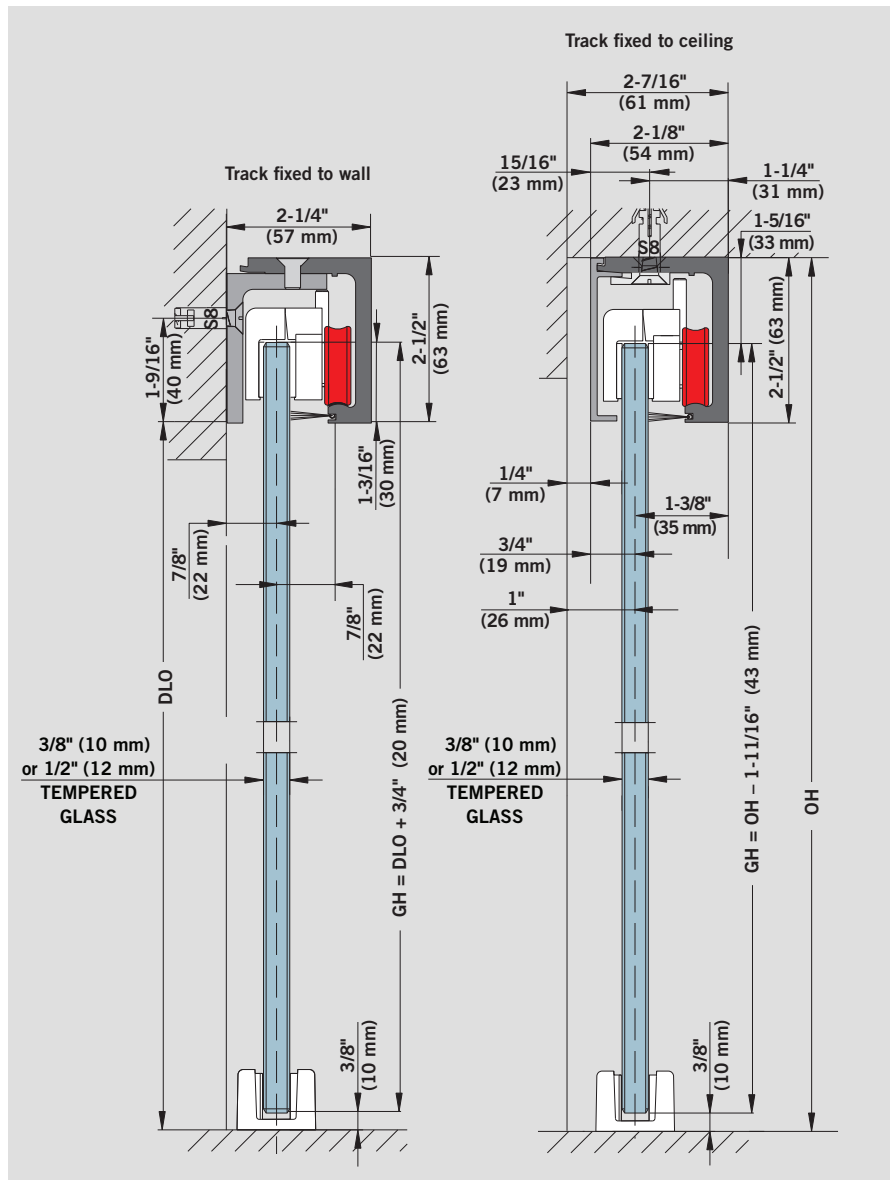

**Typical assemblies – version with sidelite**

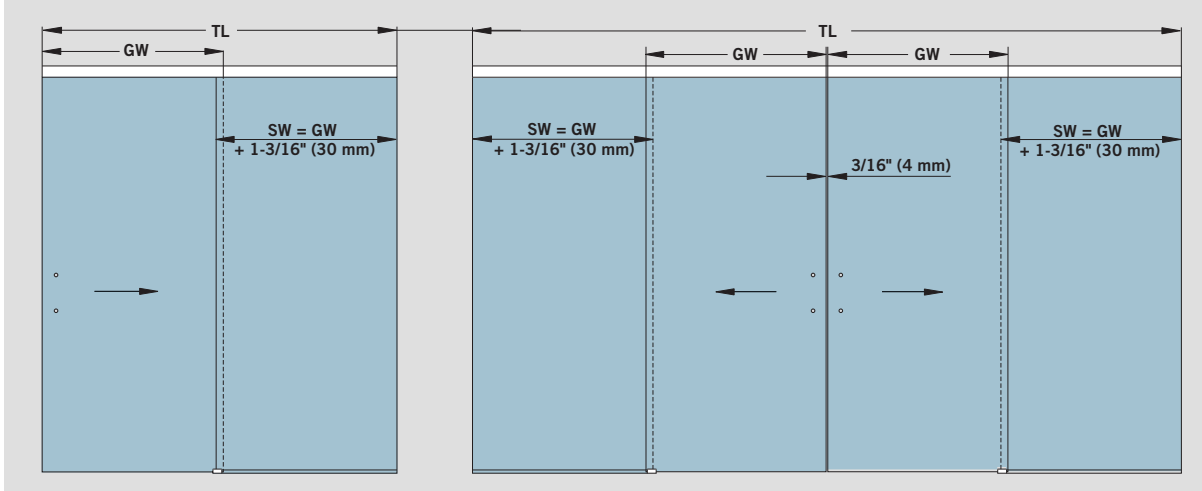

**Features and Data**

**DORMA AGILE 150**

For installations with one or two door leaves, with sidelites; for 3/8" (10 mm) and 1/2" (12 mm) glass thickness

**Max. weight of door leaves**  
330 lb (150 kg)

**Calculation of glass height**

Sliding panels:  
GH = OH - 1-11/16" (43 mm)  
(see right drawing)

Sidelites:  
SH = OH - 1-7/8" (48 mm)  
(see left drawing)

**Calculation of glass width**

Sliding panels:  
GW = TL/2  
[\*min. 19-11/16" (500 mm)]

Sidelites:  
SW = GW + 1-3/16" (30 mm)

**Torque for screws in the clamp-carriers**

9 lb-ft (12 Nm)

GW = Glass width  
(sliding panel)

TL = Track length

GH = Glass height  
(sliding panel)

SH = Sidelite height  
(fixed panel)

OH = Opening height

SW = Sidelite width  
(fixed panel)

X = 5/8" for 3/8" glass  
(16 mm for 10 mm glass)  
9/16" for 1/2" glass  
(14 mm for 12 mm glass)

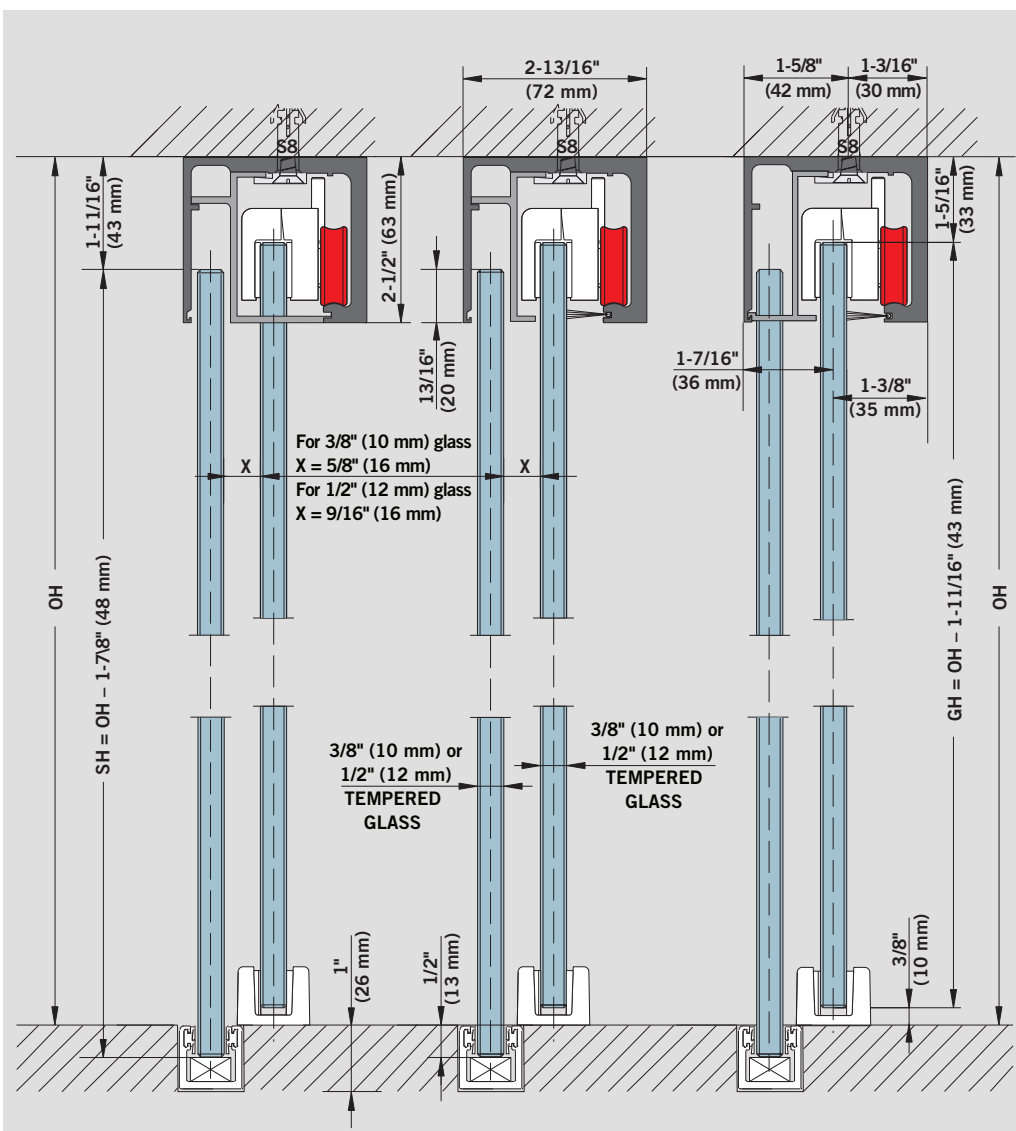

Single parts for version without sidelites

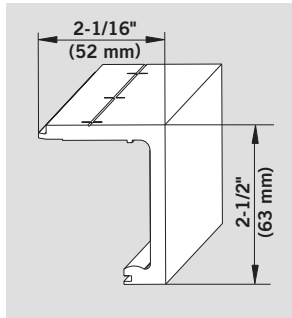

**AGILE 150 Track Profile ceiling or wall mount** (for installation without sidelites), drilled, stock length 157" (4 m)  
**Art. No. 807.340**

Weight in lb/ft (kg/m):  
1.4 (1.910)

*Cover profile 807.341/342 must be ordered separately.*

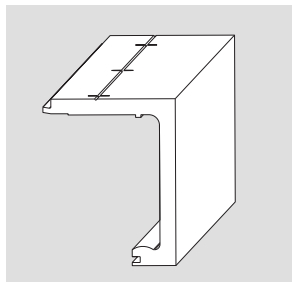

**AGILE 150 Syncro Track ceiling mount** (for installation without sidelites), stock length 157" (4 m)  
**Art No. 807.353**

*Cover profile 807.341 must be ordered separately.*

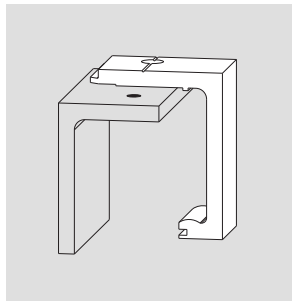

**AGILE 150 Syncro Track Profile wall mount** (for installation without sidelites), drilled, stock length 157" (4 m)  
**Art No. 807.355**  
**Art No. 807.354** (mounting between walls)

*Angle profile 807.342 must be ordered separately.*

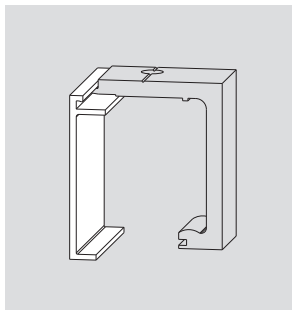

**AGILE 150 Cover Profile, ceiling mount** (for installation without sidelites), stock length 157" (4 m)  
**Art. No. 807.341**

Weight in lb/ft (kg/m):  
0.38 (0.52)

*For use with 807.340/353 Track Profile.*

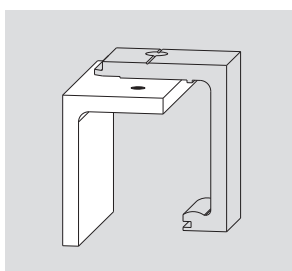

**AGILE 150 Angle Profile, wall mount**, drilled, stock length 157" (4 m)  
**Art. No. 807.342**

Weight in lb/ft (kg/m):  
1.06 (1.450)

*For use with 807.340/355 Track Profile.*

Single parts for version with sidelites

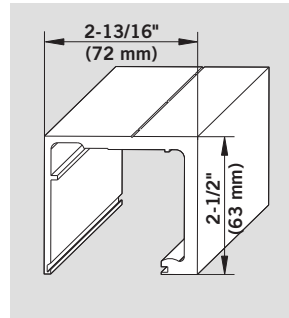

**AGILE 150 Track Profile ceiling mount**, drilled (for installation with sidelites), stock length 157" (4 m)  
**Art. No. 807.360**

Weight in lb/ft (kg/m):  
1.92 (2.623)

*The sidelite/edge profile 807.361 and view protection profile 807.362 must be ordered separately.*

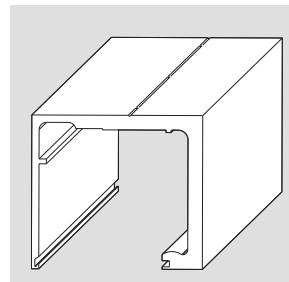

**AGILE 150 Syncro Track ceiling mount** (for installation with sidelites), stock length 157" (4 m)  
**Art No. 807.373**

*The sidelite/edge profile 807.361 and view protection profile 807.362 must be ordered separately.*

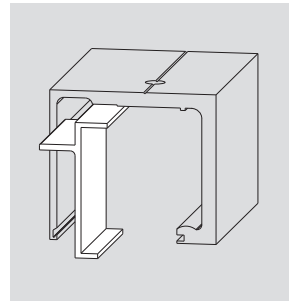

**AGILE 150 Sidelite ceiling mount profile** (for installation with sidelites), stock length 157" (4 m)  
**Art. No. 807.361**

Weight in lb/ft (kg/m):  
0.26 (0.348)

*For use with 807.360/373.*

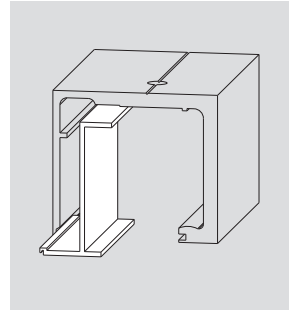

**AGILE 150 View Protection ceiling mount profile**, to cover gap in entry area (for installation with sidelites), stock length 157" (4 m)  
**Art. No. 807.362**

Weight in lb/ft (kg/m):  
0.30 (0.405)

*For use with 807.360/373.*

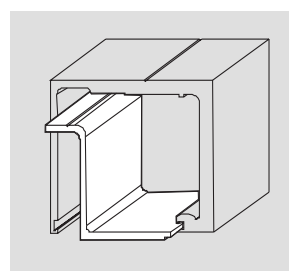

**AGILE 150 Sidelite Inlaid profile, ceiling mount** to cover gap in sidelite area (for installation with sidelites), stock length 157" (4 m)  
**Art. No. 807.364**

*For use with 807.360/373 track.*

**AGILE 150/AGILE 150 Syncro Accessories**

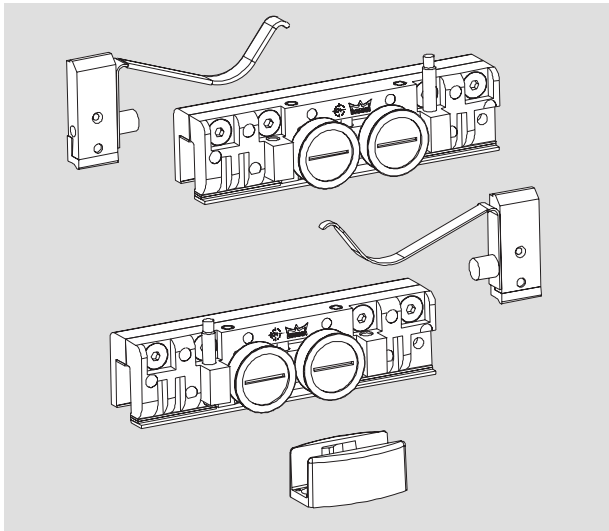

**AGILE 150 accessory set**

Max. panel width:  
54" (1400 mm)  
Max. panel weight:  
330 lb (150 kg)

Set includes:  
2 clamp-carriers (for 3/8"  
(10 mm) or 1/2" (12 mm)  
glass thickness)  
with stabilizer, 2 endstops  
with safety catch,  
1 AGILE floor guide

**Art. No. 807.325\***

Weight in lb/ft (kg/m):  
2.98 (1.354)

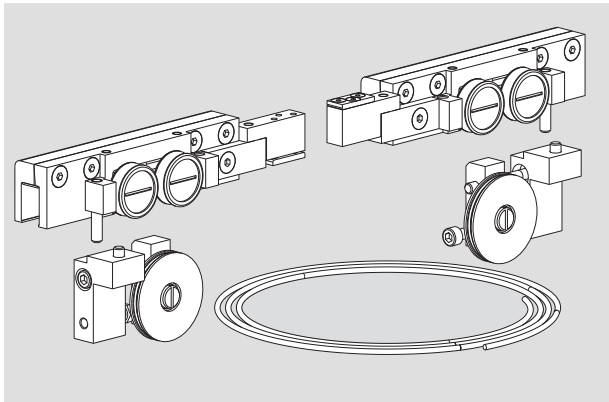

**AGILE 150 Syncro set**  
for 2-panel synchronously  
opening system.

Max. panel width:  
39-3/8" (1000 mm)  
Max. panel weight:  
176 lb (80 kg)

Set includes:  
2 x accessory set  
Art. No. 807.325,  
1 x deflection device  
incl. cable, adjustable

**Art. No. 807.330**

*Track profiles etc. to be  
ordered separately.*

**NOTE:** AGILE track rail/wall  
angle must be prepared for  
syncro system before  
installing it.

**Please read the mounting  
instructions carefully.**

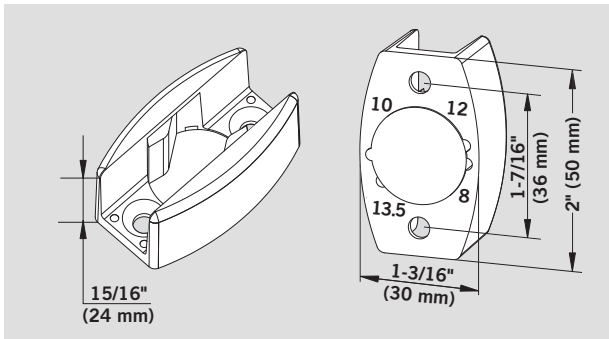

**AGILE 150 floor guide,**  
adjustable for 3/8" (10 mm),  
1/2" (12 mm), and 9/16"  
(13.5 mm) glass thickness

**Art. No. 807.326**

Weight in lb/ft (kg/m):  
0.21 (0.094)

**\* If replacement parts are  
required, please mention  
the date of purchase.**

**AGILE 150 End Cap**

**AGILE 150 endcap**  
**2-1/8" (54 mm)**  
for ceiling mount track  
Art. No. 807.340/341  
**Art. No. 807.327**  
Weight in lb (kg):  
0.03 (0.014)

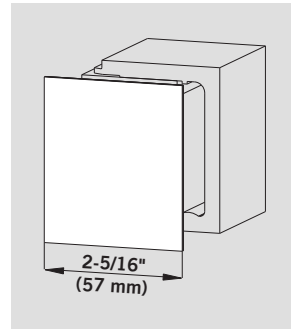
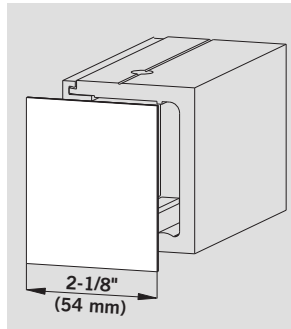

**AGILE 150 endcap**  
**2-1/4" (57 mm)**  
for wall mount track  
Art. No. 807.340/342  
**Art. No. 807.328**  
Weight in lb (kg):  
0.03 (0.014)

**AGILE 150 endcap**  
**2-7/8" (72 mm)**  
for track with  
sidelite installation  
Art. No. 807.360  
**Art. No. 807.329**  
Weight in lb (kg):  
0.03 (0.014)

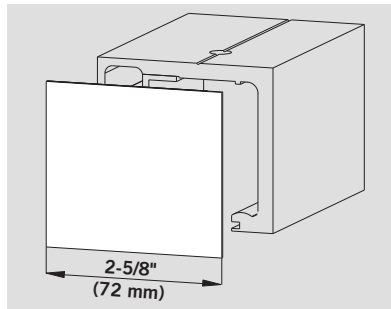

**AGILE 150 Brush Profile**

**Brush profile,**  
for gaps up to 1/2" (13 mm),  
stock length 118" (3 m)  
**Art. No. 807.400**

**Brush profile,**  
for gaps up to  
1 1/16" (18 mm),  
stock length 118" (3 m)  
**Art. No. 807.402**

**Track brush**  
**Art. No. 807.385**  
stock length 49" (1.3 m)

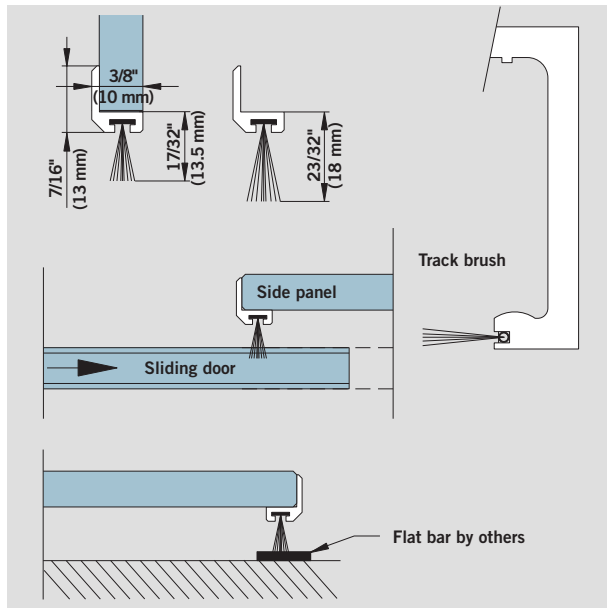

**NOTE:** Various weights and measures in metric units. Refer to page 19 for Metric/English conversion.

## DORMA RS 120/RS 120 Syncro/DRS 120 Rugged construction – easy operation



### Rugged track

The DORMA RS 120 and DRS 120 feature a hollow profiled aluminum track that is light, yet rugged and resistant to twisting. It can be mounted directly under the ceiling or onto a wall. Cutting to the required size is simplicity itself. The raised, convex profile of the rail surface prevents dust and dirt collecting.

### Clip-on covers

The RS 120 covers are aluminum and easily clipped onto the track. If the track is top mounted onto the ceiling, the covers are used on both sides; if the track is side mounted, the cover is used on the exposed side only. The covers also can easily be cut to size.

The DRS 120 utilizes the RS track with DORMA DRS clamp-on rails. Rail heights are available in 3-5/8", 4", 6", 8", and 10" tall. Snap-on covers make installation quick and easy.

### Sidelite profile

A special profile to be hung and screwed into the track is available for systems that include fixed sidelites. The sidelite profile ensures the correct mounting distance between the glass and the track. Sidelite profiles can be provided with clip-on covers. Also, protection profiles are available to cover from below where sidelite profiles are exposed in the passage area.

### Gentle, easy action

The carriers run on large nylon wheels with needle

bearings, giving a quiet and very low friction ride. They are made from high grade, glass-fiber-reinforced nylon, which is corrosion resistant and extremely strong.

### End stop and holder

An ingenious device within the track operates as a cushioned end stop, retaining the door securely in the end positions.

### Syncro Version

The RS 120 Syncro features a cable and deflection device for synchronously opening a bi-panel installation. Opening one panel automatically opens the other, so a minimum of effort leads to the maximum opening width.

### No glass preparation

DORMA Glas has extensive experience working with tempered glass, which has led to the development of a mechanism for clamping glass panels within the DORMA RS sliding-door gear. Drilling or cutting the glass panels is unnecessary. The clamping mechanism also allows you the flexibility of adjusting the height of the doors after they've been hung, without dismantling them.

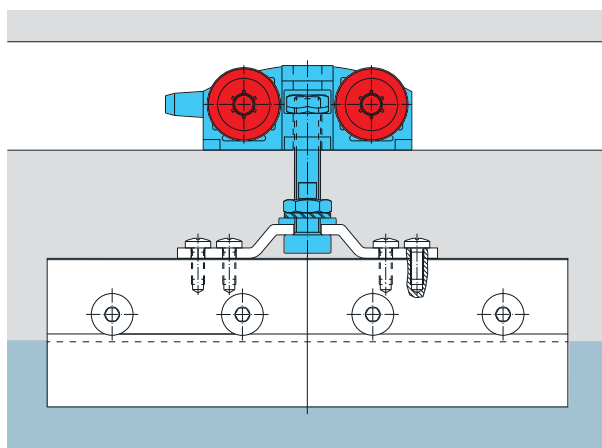

Typical assemblies

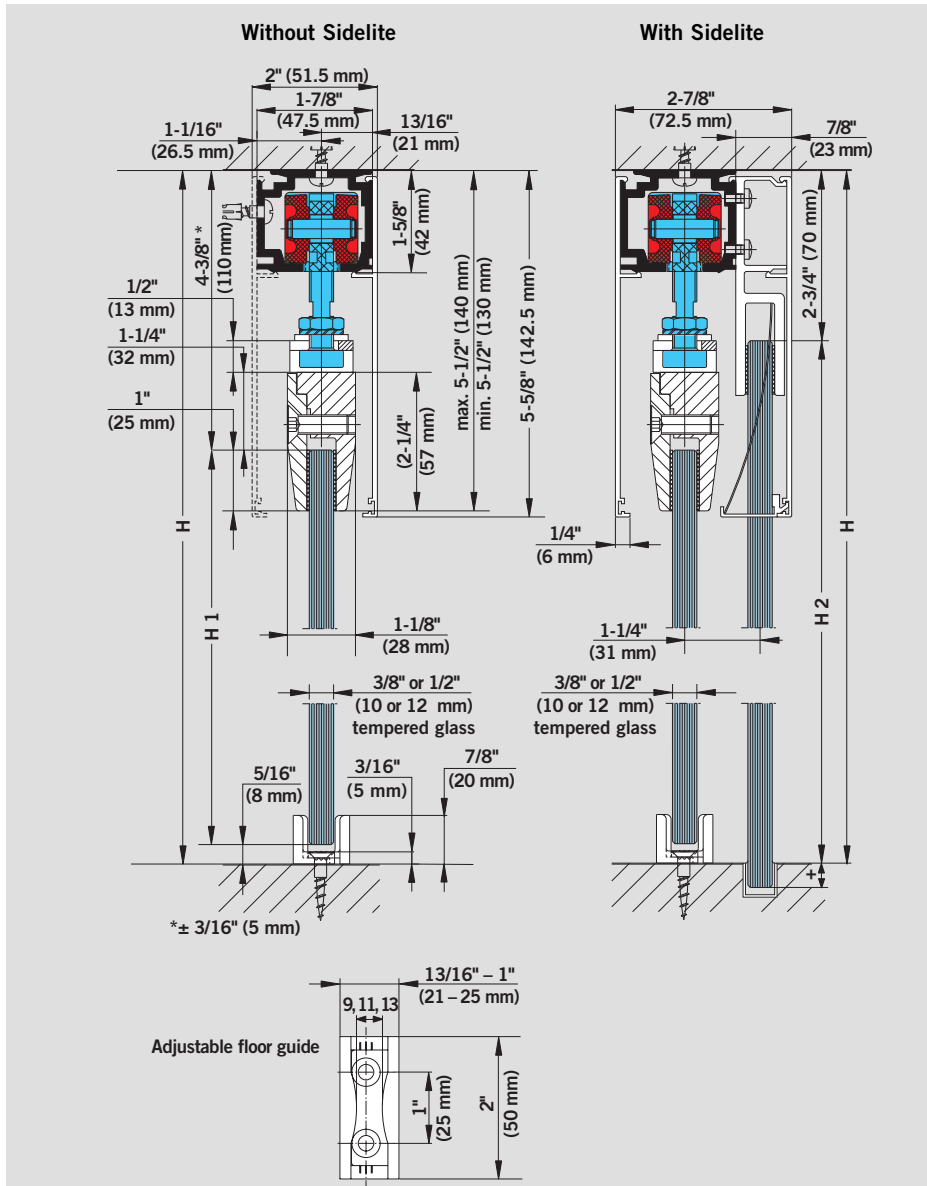
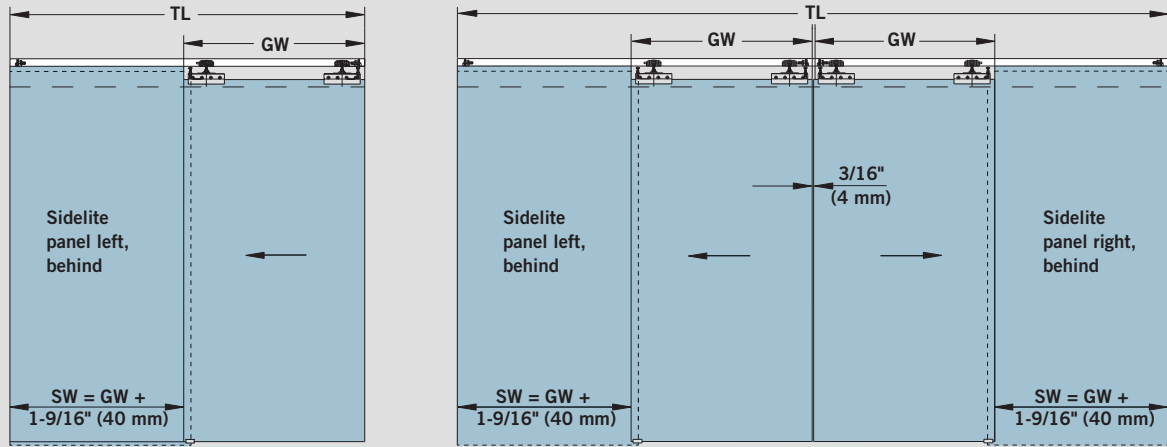

Features and Data

DORMA RS 120

For one or more door leaves, with or without sidelites; 3/8" (10 mm) and 1/2" (12 mm) glass thickness.

Maximum weight of door leaves

No. of carriers	max weight per door leaf
2	264 lb (120 kg)
3	330 lb (150 kg)

Calculation of glass height

Height of sliding door leaf  
GH = OH - 4-5/8" (118 mm)  
(see left drawing)

Height of sidelite  
SH = OH - 2-3/4" (70 mm)  
+ insert into floor (see right drawing)

Calculation of glass width

Width of sliding door leaf  
GW = TL/2 [min. 19-11/16" (500 mm)]

Width of sidelite  
SW = GW + 1-9/16" (40 mm)

Torque for screws in the clamping patches

15 lb-ft (20 Nm)

GW = Glass width

TL = Track length

GH = Glass height

(sliding panel)

SH = Sidelite height

(fixed panel)

OH = Opening height

SW = Sidelite width

Typical assemblies

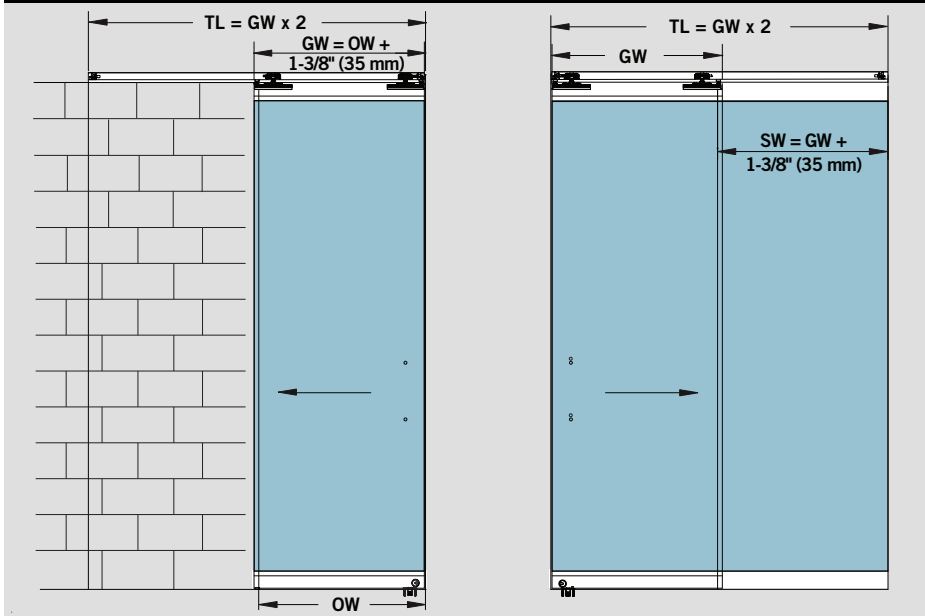

Features and Data

DORMA DRS 120

For one or more door leaves, with or without sidelites; 3/8" (10 mm) and 1/2" (12 mm) glass thickness.

Maximum weight of door leaves

No. of carriers	max weight per door leaf
2	264 lb (120 kg)
3	330 lb (150 kg)

Calculation of glass height

Height of sliding door leaf  
GH = OH - 5-15/16" (151 mm)

Height of sidelite  
SH = OH - 6-3/4" (171 mm)

Calculation of glass width

Width of sliding door leaf  
GW = OW + 1-3/8" (35 mm)

Width of sidelite  
SW = GW + 1-3/8" (35 mm)

Torque for screws in the clamping patches

15 lb-ft (20 Nm)

OH = Opening height

OW = Opening width

TL = Track length

GW = Glass width

SW = Sidelite width

GH = Glass height

SH = Sidelite height

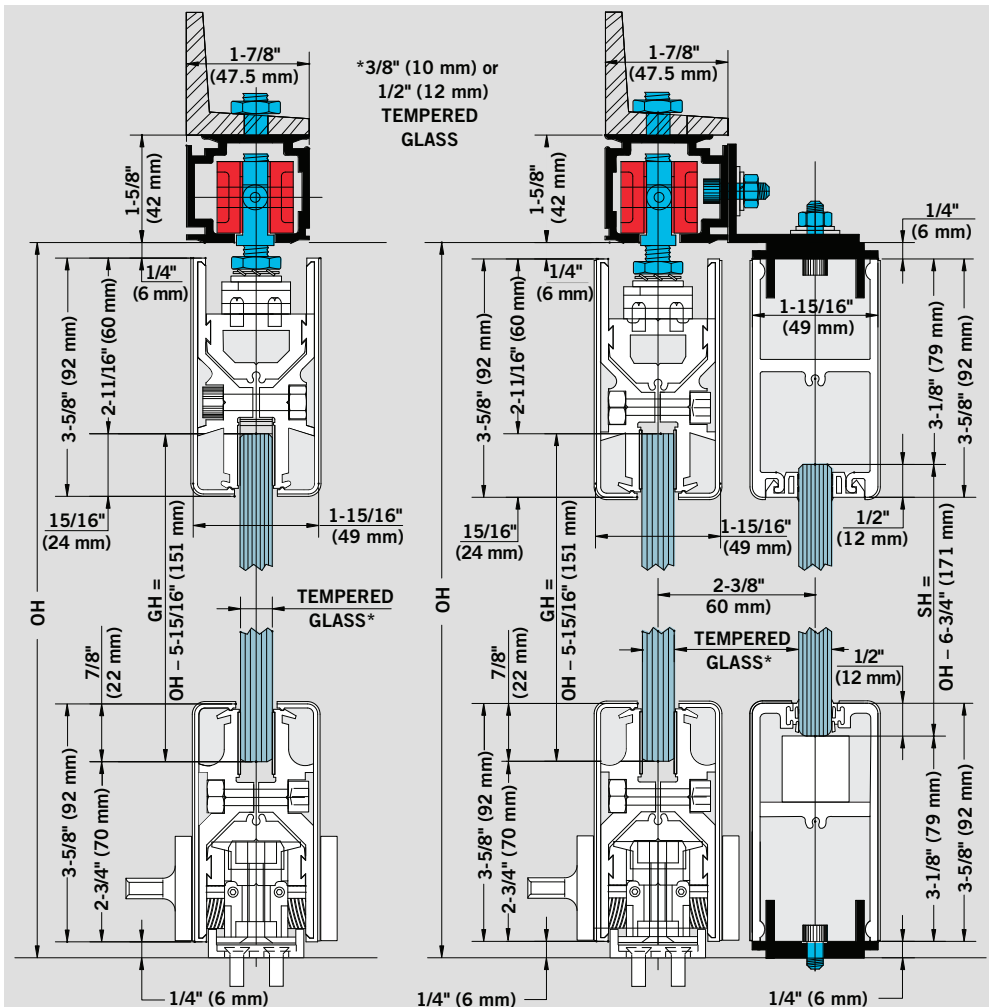

NOTE: Various weights and measures in metric units. Refer to page 19 for Metric/English conversion.

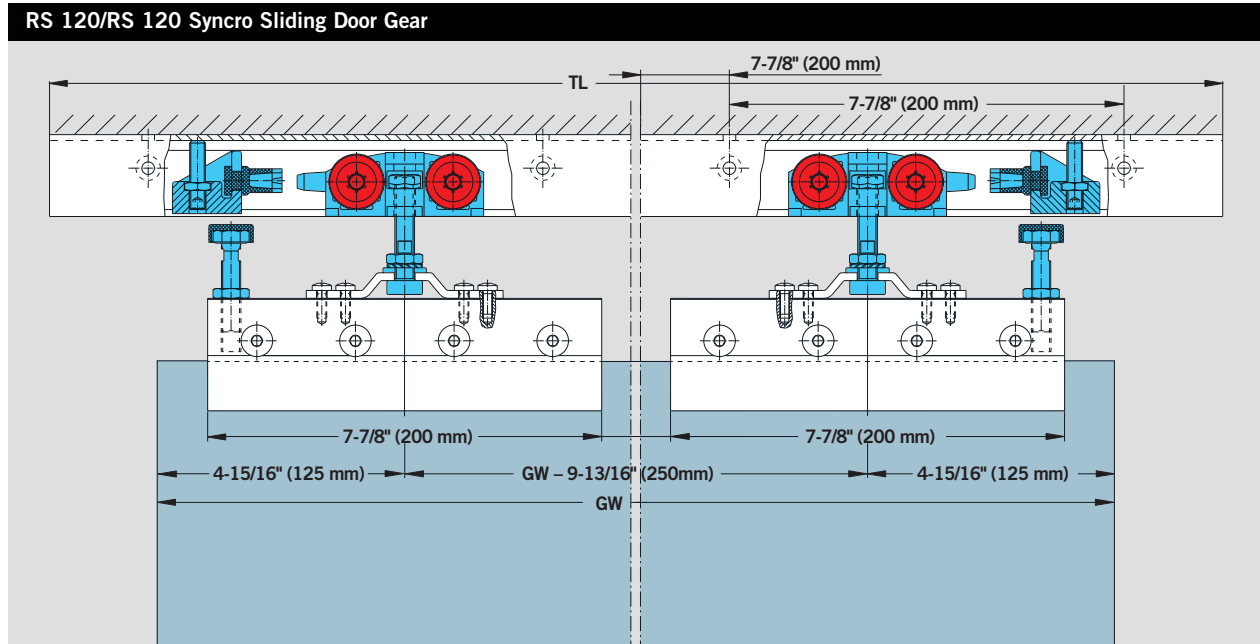

**Sliding door gear RS 120**  
consisting of 1 track,  
2 carriers with clamping  
patches and support screw  
for 3/8" (10 mm) and 1/2"  
(12 mm) glass thickness,  
2 end stops, and 1 floor  
guide.

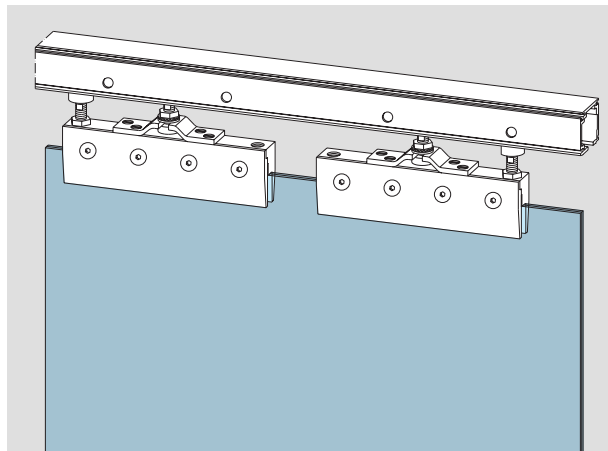

**Sliding door gear  
RS 120 Syncro**  
For 2-panel synchronously  
opening system,  
max. panel width =  
2 × 39-3/8" (1000 mm)  
max. panel weight =  
176 lb (86 kg)  
per panel, consisting of:  
2 × accessory set 907.125  
1 × deflection device incl.  
cable, adjustable  
**Art. No. 907.150**

*The following parts must be  
ordered separately: sidelite  
profile, cover profile, view  
protection profile.*

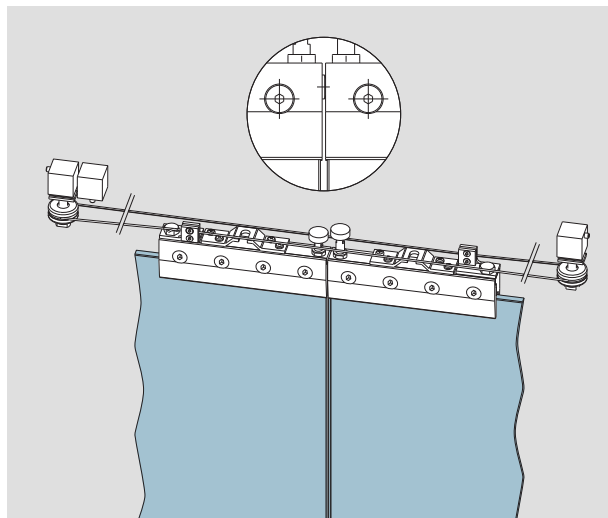

Individual parts RS 120/RS 120 Syncro/DRS 120

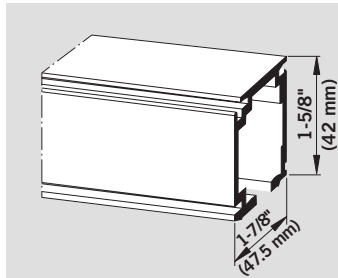

**RS Track** prepared for ceiling or wall mount, stock length 157" (4 m)  
**Art. No. 907.121**  
Weight in lb/ft (kg/m):  
0.99 (1.355)

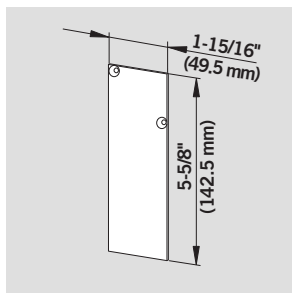

**Endcap**  
track connected to ceiling, incl. screws  
**Art. No. 907.129**  
Weight in lb (kg):  
0.08 (0.037)

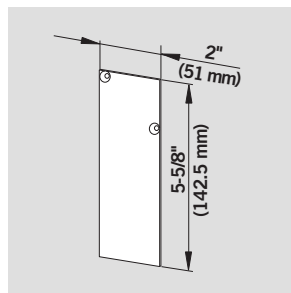

**Endcap**  
track connected to wall, incl. screws  
**Art. No. 907.127**  
Weight in lb (kg):  
0.08 (0.037)

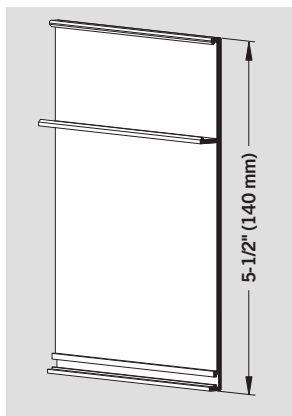

**RS Cover profile**  
stock length 157" (4 m)  
\*Snap on covers for RS Track 907.121  
**Art. No. 907.140**  
Weight in lb/ft (kg/m):  
0.61 (0.826)

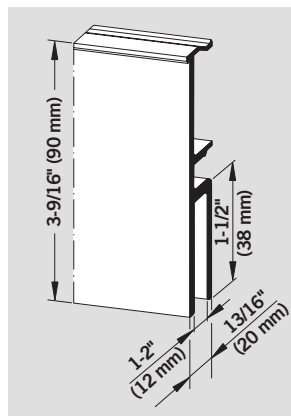

**RS Sidelite profile**  
connectable to track, non prepared, stock length 157" (4 m)  
**Art. No. 907.122**  
Weight in lb/ft (kg/m):  
1.23 (1.680)

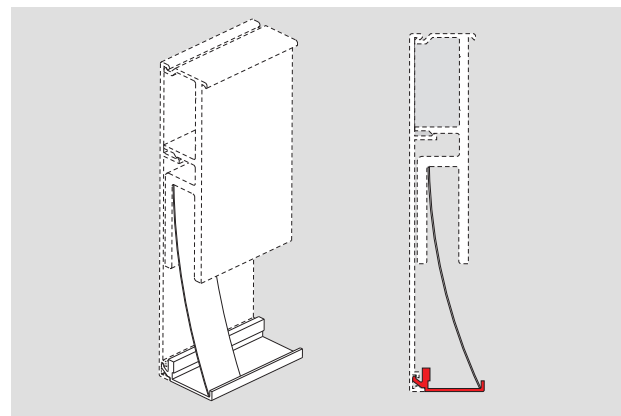

**RS Bottom view protection profile**  
(only in combination with sidelite profile 07.122 and cover profile 07.140)  
stock length 157" (4 m)  
**Art. No. 907.138**  
Weight in lb/ft (kg/m):  
0.12 (0.164)

**NOTE:** Various weights and measures in metric units. Refer to page 19 for Metric/English conversion.

RS 120/RS 120 Syncro Accessories

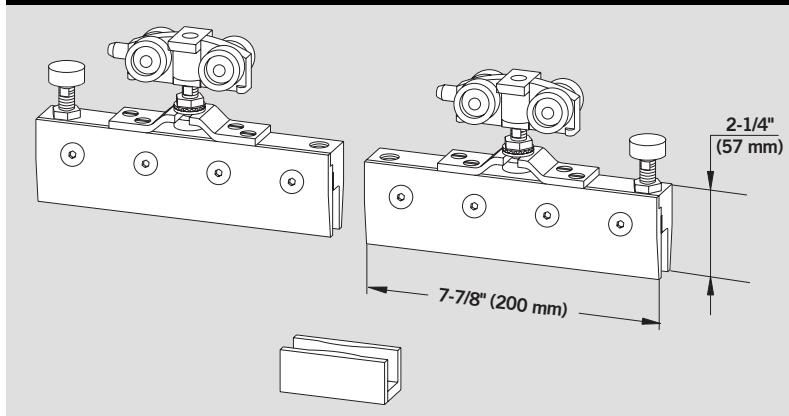

**Set of accessories for RS 120**  
consisting of  
2 carriers with clamping  
patches— $3/8$ " (10 mm)  
and  $1/2$ " (12 mm) glass  
thickness—and support  
screw, 2 end stops with  
safety catch, 1 floor guide  
**Art. No. 907.125**

**Set of accessories for RS 120 Syncro**  
consisting of  
2 × Art No. 907.125,  
Syncro cable  
**Art. No. 907.160**  
**Additional carrier with  
clamping patches—**  
 $3/8$ " (10 mm) and  $1/2$ "  
(12 mm) thickness—for  
max. panel weight 330 lb  
**Art. No. 907.123**

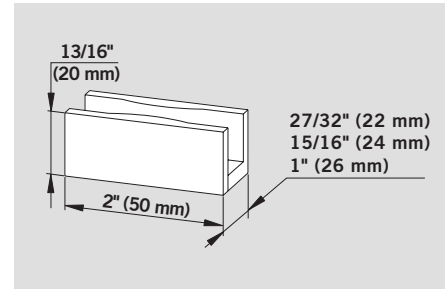

**RS 120/RS120 Syncro  
floor guide,  
adjustable  
Art. No. 907.126**  
Weight in lb (kg):  
0.05 (0.024)

DRS 120 Accessories

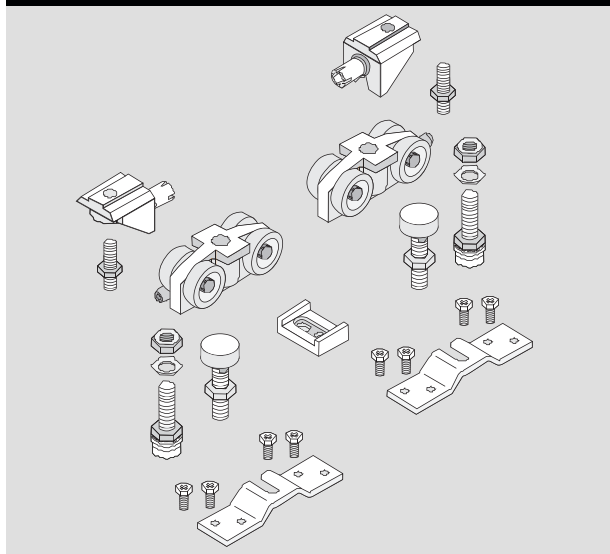

**Set of accessories for DRS 120**  
consisting of  
2 rollers with mounting  
brackets and guide,  
2 end stops, 1 floor guide  
**Art. No. – consult factory**

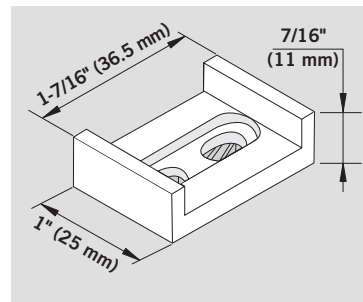

**DRS120 floor guide,  
adjustable  
Art. No. 932.988**  
Weight in lb (kg):  
0.05 (0.024)

## DORMA RSP 80 Saving space – creating room

The smooth and clean design of the DORMA RSP ensures unparalleled ease of operation in a sliding door. The aluminum track is a round extrusion with a special support profile for direct wall mounting. A flush plastic extrusion clips into the track rail to provide the running surface. Resting on this surface, the roller carriers—essential to the visual effect—quietly guide the sliding panel to the desired position, rolling unhindered to a safe stop every time.

All the visible metal components of the RSP 80 are manufactured in aluminum and feature an attractive satin finish. In addition to the standard EV1 Deco finish (similar to Clear Anodized aluminum), numerous special anodized finishes can be provided upon request. With its variety of color options, the RSP 80 will always blend perfectly with its surroundings.

The RSP 80 is designed for a standard opening, clear width of approximately 39-3/8" (1000 mm) and a maximum door weight of 176 lbs (80 kg). A complete set of hardware and fittings for one sliding glass door is supplied as a package. The RSP 80 system is easy and quick to install, simple to use, and alluring in appearance.

### **Minimal gap dimensions**

Design specifications automatically ensure very small gap dimensions between glass and wall surfaces.

### **Sophisticated track roller assembly—secure hold**

The RSP 80 satisfies a wide range of customer

requirements: its two visible and maintenance-free roller carriers are rated to support glass panels of up to 176 lb (80 kg). A total of four holes drilled in the glass serve to efficiently hang the glass panel on two rollers. Proven track roller engineering ensures smooth and quiet operation. In terms of ease of operation, the RSP 80 satisfies the Class 3 EN 1527 criteria, which requires that just 4% of the door mass has to be overcome

as initial force in order to start the door in motion.

### **Safe stopping**

During both opening and closing cycles the doors are gently decelerated by a grip-type buffer in their ending positions.

### **Elegant floor guide**

The innovative and attractive AGILE floor track incorporates an adjustment system for accommodating different glass thicknesses. A rotating plastic insert securely

positions glass panels from 5/16" (8 mm) to 9/16" (13.5 mm) thick.

### **Long service life—corrosion resistance**

Protracted tests comprising over 50,000 motion cycles (to EN 1527) have proven the RSP 80 to have a long service life. The RSP 80 also offers a high level of corrosion resistance, making these fittings suitable for use in wet rooms.



**Typical assembly**

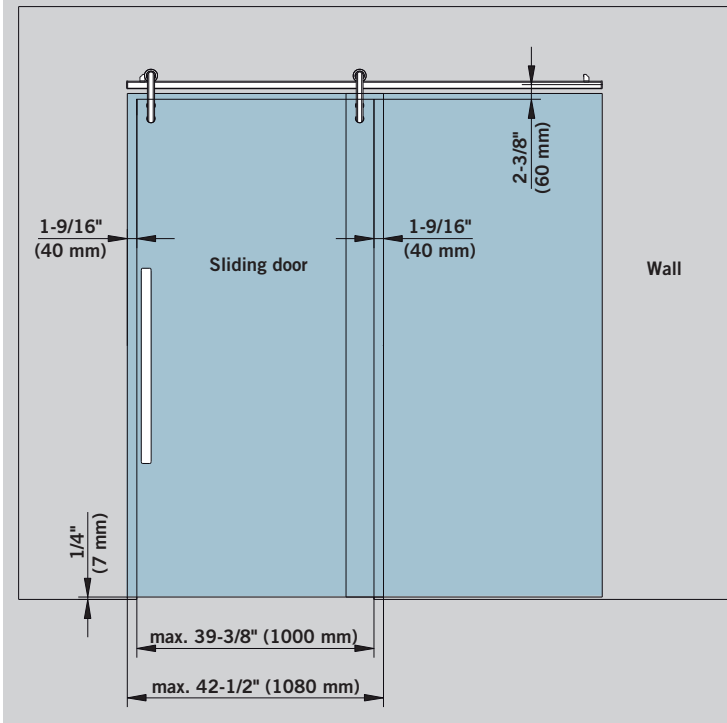

**Set components for glass applications**

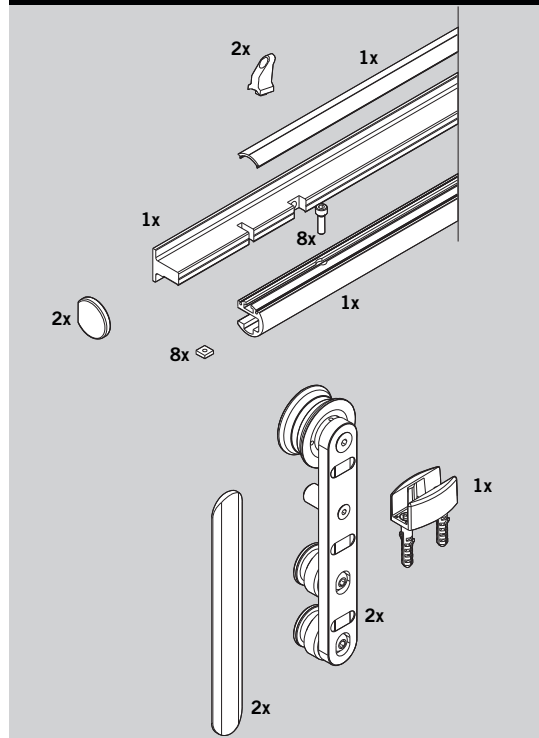

**Preparation for glass applications**

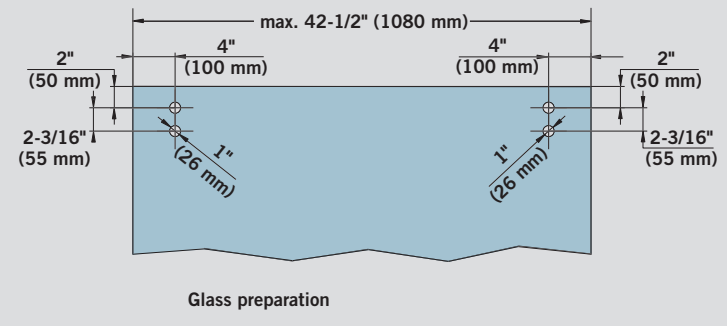

**DORMA RSP 80 sliding door set for  $3/8"$  (10 mm) glass** consisting of track profiles for max. panel width  $42\text{-}1/2"$  (1080 mm), roller, stopper, and floor guide, finish Aluminum EV1 Deco (similar to Clear Anodized)  
**Art. No. 830.700**  
Weight in lb (kg):  
12.34 (5.6)

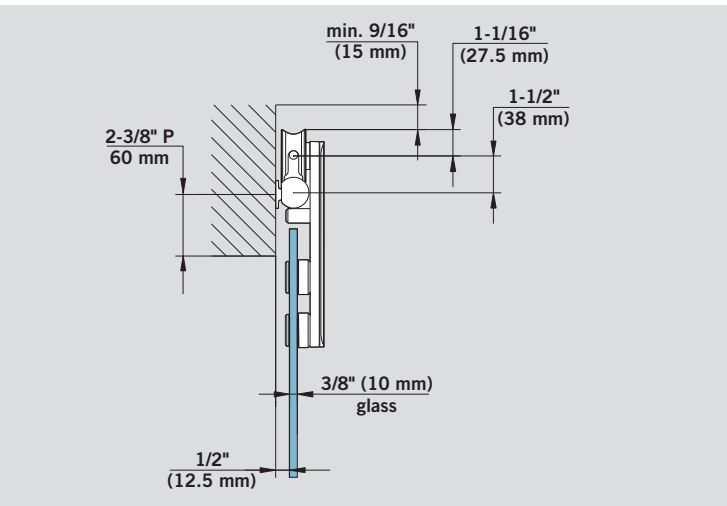

**Single components**

**Roller, carrier, stop, and floor guide:**  
**Art. No. 830.701**

**RSP 80 track profile for mounting to wall**  
stock length  $157"$  (4 m)  
**Art. No. 830.705**

**RSP 80 track profile for mounting to wall**  
in fixed length (min. door width should not go below  $31\text{-}1/2"$  [800 mm] /  $63"$  [1600] track profile)  
**Art. No. 830.706**

**Set components for wood applications**

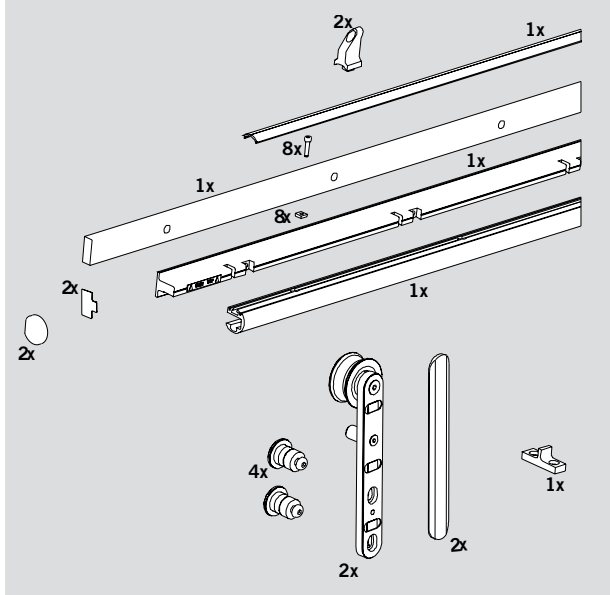

**DORMA RSP 80 sliding door set for wood applications** consisting of track profiles for max. panel width 42-1/2" (1080 mm), roller, stopper, and floor guide, finish Aluminum EV1 Deco (similar to Clear Anodized)  
**Art. No. 830.707**

Weight in lb (kg):  
12.34 (5.6)

**Single components**

**Roller, carrier, stop, and floor guide for wood applications**  
**Art. No. 830.708**

**RSP 80 track profile for mounting to wall (wood application)**  
stock length 157" (4 m)  
**Art. No. 830.712**

**RSP 80 track profile for mounting to wall (wood application)**  
in fixed length (min. door width should not go below 31-1/2" [800 mm] / 63" [1600] track profile)  
**Art. No. 830.713**

**Preparation for wood applications**

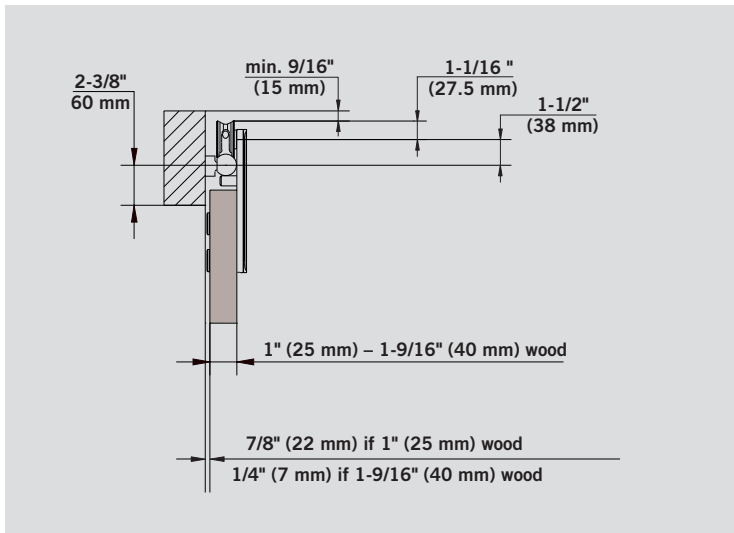
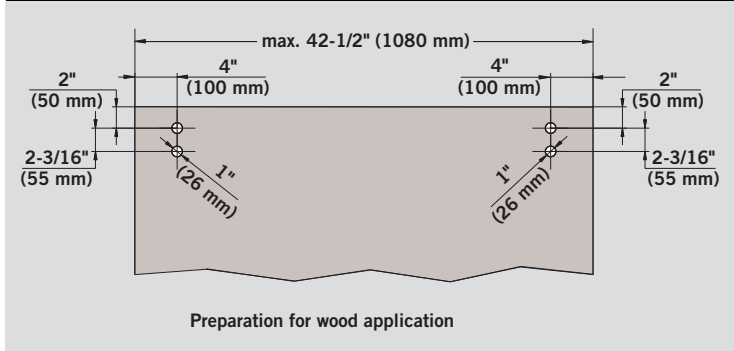

**NOTE:** Various weights and measures in metric units. Refer to page 19 for Metric/English conversion.

General Accessories

**Hook lock**

for sliding doors, prepared for Europrofile cylinder, left hand and right hand, with lock keeper plate, suitable for lever handles with follower

**Art. No. 905.202**

Weight in lb (kg):  
aluminum 2.92 (1.325)

**Strike box**

to suit hook lock (905.202), non-handed, only to be used with bi-parting systems

**Art. No. 905.201**

Weight in kg:  
aluminum 0.890

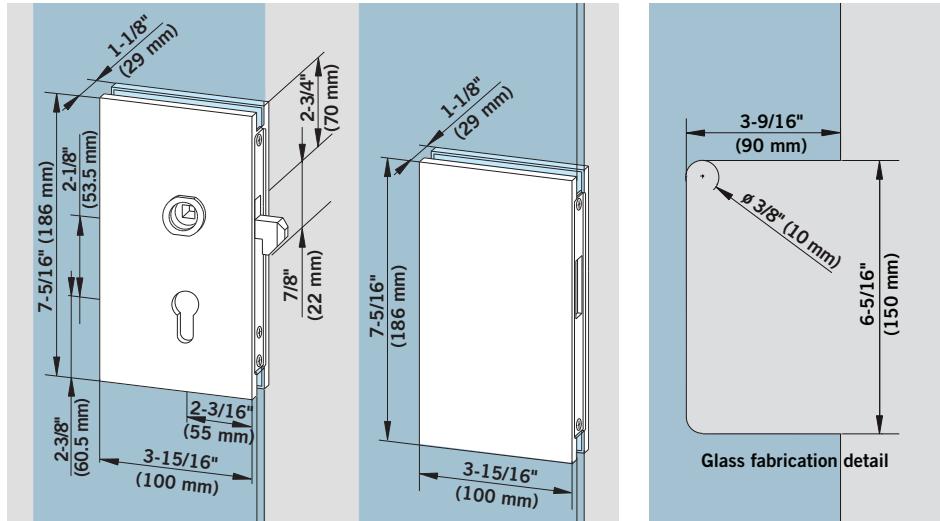

\*Left/right hand (illustration shows left hand) is determined by view from hanging side.

**Set of lever handles**

**Flat handles**

Available in 101 Clear Anodized or 107 Aluminum similar to Satin Stainless Steel finishes

**Art. No. 910.314**

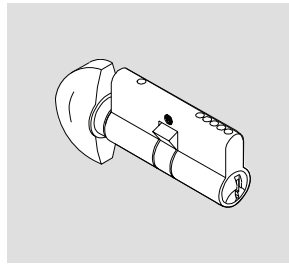
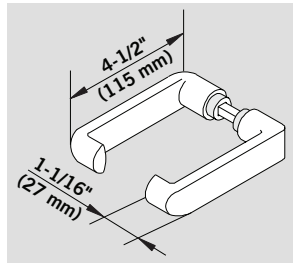

**Europrofile cylinder**

key/thumbturn, handed (please specify right/left hand)

**Art. No. 901.004 (LH)**

**Art. No. 901.002 (RH)**

**Set of lever handles**

**Tubular handles**

Available in 101 Clear Anodized or 107 Aluminum similar to Satin Stainless Steel finishes

**Art. No. 910.310**

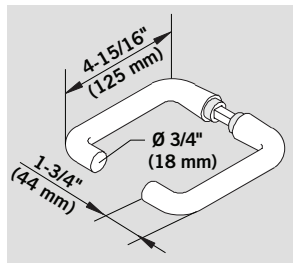

**Flush pull,**

aluminum, to be glued onto the glass—requires glass cut

**Art. No. 907.200**

Weight in lb (kg):  
0.16 (0.072)

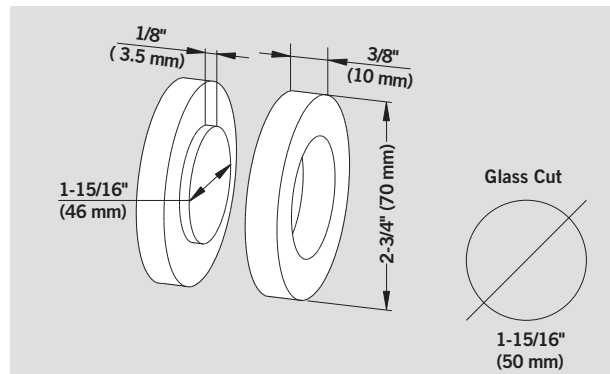

**Metric/English Conversion**

**kg/lb conversion** To convert to pounds, multiply kilograms by 2.2.

**inch/mm conversion** To convert to millimeters, multiply inches by 25.4.  
To convert to inches, divide millimeters by 25.4 or multiply millimeters by 0.03937.

INCHES			INCHES			INCHES		
Fractional	Decimal	METRIC mm	Fractional	Decimal	METRIC mm	Fractional	Decimal	METRIC mm
1/32	0.0313	0.7938		0.9055	23	2-1/2	2.5	63.5
	0.0394	1	29/32	0.90625	23.0188		2.5197	64
1/16	0.0625	1.5875	15/16	0.9375	23.8125		2.5591	65
	0.0787	2		0.9449	24		2.5984	66
3/32	0.0938	2.3813	31/32	0.96875	24.6063		2.6378	67
	0.1181	3		0.9843	25		2.6772	68
1/8	0.125	3.175	1	1	25.4		2.7165	69
5/32	0.1563	3.9688		1.0236	26	2-3/4	2.75	69.85
	0.1575	4		1.063	27		2.7559	70
3/16	0.1875	4.7625		1.1024	28		2.7953	71
	0.1969	5		1.1417	29		2.8346	72
7/32	0.2188	5.5563		1.1811	30		2.874	73
	0.2362	6		1.2205	31		2.9134	74
1/4	0.25	6.35	1-1/4	1.25	31.75		2.9528	75
	0.2756	7		1.2598	32		2.9921	76
9/32	0.2813	7.1438		1.2992	33	3	3	76.2
5/16	0.3125	7.9375		.3386	34		3.0315	77
	0.315	8		1.378	35		3.0709	78
11/32	0.3438	8.7313		1.4173	36		3.1102	79
	0.3543	9		1.4567	37		3.1496	80
3/8	0.375	9.525		1.4961	38		3.189	81
	0.393	10	1-1/2	1.5	38.1		3.2283	82
13/32	0.4063	10.3188		1.5354	39		3.2677	83
	0.4331	11		1.5748	40		3.3071	84
7/16	0.4375	11.1125		1.6142	41		3.3465	85
15/32	0.4688	11.9063		1.6535	42		3.3858	86
	0.4724	12		1.6929	43		3.4252	87
1/2	0.5	12.7		1.7323	44		3.4646	88
	0.5118	13	1-3/4	1.75	45.45	3-1/2	3.5	88.9
17/32	0.5313	13.4938		1.7717	45		3.5039	89
	0.5512	14		1.811	46		3.5433	90
9/16	0.5625	14.2875		1.8504	47		3.5827	91
	0.5906	15		1.8898	48		3.622	92
19/32	0.5938	15.0813		1.9291	49		3.6614	93
5/8	0.625	15.875		1.9685	50		3.7008	94
	0.6299	16	2	2	50.8		3.7402	95
21/32	0.6563	16.6688		2.0079	51		3.7795	96
	0.6693	17		2.0472	52		3.8189	97
11/16	0.6875	17.4625		2.0866	53		3.8583	98
	0.7087	18		2.126	54		3.8976	99
23/32	0.7188	18.2563		2.1654	55		3.937	100
	0.748	19		2.2047	56	4	4	101.6
3/4	0.75	19.05		2.2441	57		4.3307	110
25/32	0.7813	19.8438	2-1/4	2.25	57.15	4-1/2	4.5	114.3
	0.7874	20		2.2835	58		4.7244	120
13/16	0.8125	20.6375		2.3228	59	5	5	127
	0.8268	21		2.3622	60		5.1181	130
27/32	0.8438	21.4313		2.4016	61		5.5118	140
	0.8661	22		2.4409	62		5.9055	150
7/8	0.875	22.225		2.4803	63	6	6	152.4

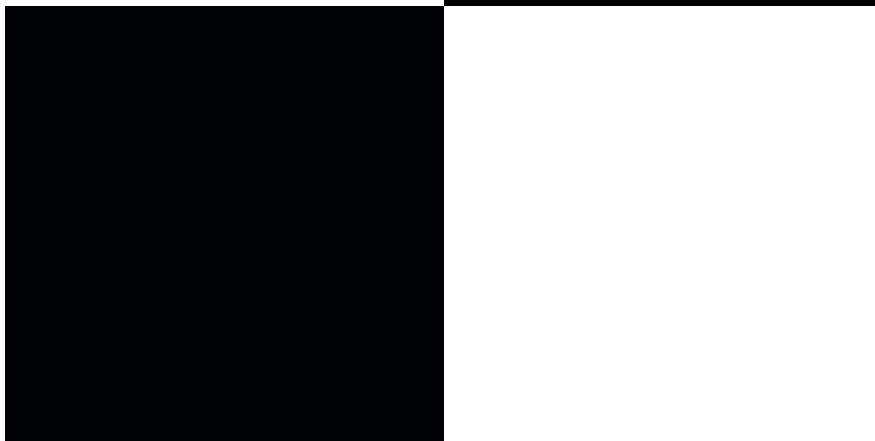

DORMA Glas, Inc.  
1520 Jabez Run  
Suite 303  
Millersville, MD 21108  
Tel: 410.923.0890  
Toll Free: 800.451.0649  
Fax: 410.923.3060  
E-mail: [glas@dorma-usa.com](mailto:glas@dorma-usa.com)  
[www.dorma-usa.com](http://www.dorma-usa.com)